



RAASM UNIVERSAL MOBILE OIL SUCTION DRAINER

The RAASM Pantograph Oil Suction Drainers are universal oil drainers that can be used to change the oil of all motor vehicles.

Air Operated - Waste oil can be collected whether by gravity, using the recovering basin on the floor or in the upper position if vehicles are over car lift, or by suction through the supplied probes. (Oil must be hot at 70-80 C.

After depressurisation the drainer works independently without

FEATURES & BENEFITS:

- By gravity with drain tray on the floor
- By gravity with drain tray raised with a motor vehicle on a lift or pit
- By suction with a probe (the oil must be hot at 70-80 C)
- 65L or 115L tank capacity and 50L bowl capacity
- Level Gauge
- Cantilever arms & removable drip tray
- NOTE: Item is supplied in 4 boxes



AF-RA-46065



AF-RA-46215

SPECIFICATIONS:

| | |
|-----------------------------------|---------------|
| Air pressure for depressurisation | 6.5 - 7 bar |
| Noise level | 75 dB |
| Suction speed | 1.5 - 2 L/min |
| Discharging/Suction hose | 2 m / 2 m |
| Max pressure for discharging | 0.5 bar |
| Discharging/Suction hose | 2 m / 2 m |

| PART NO. | | TANK CAPACITY | MAX DRAINING CAPACITY | BOWL CAPACITY | WEIGHT |
|-------------|---|---------------|-----------------------|---------------|--------|
| AF-RA-46065 | RAASM 65L Universal Mobile Oil Suction Drainer | 65 L | 52 L | 14 L | 43 Kg |
| AF-RA-46215 | RAASM 115L Universal Mobile Oil Suction Drainer | 115 L | 97 L | 50 L | 68 Kg |



OVERALL DIMENSIONS (MM)

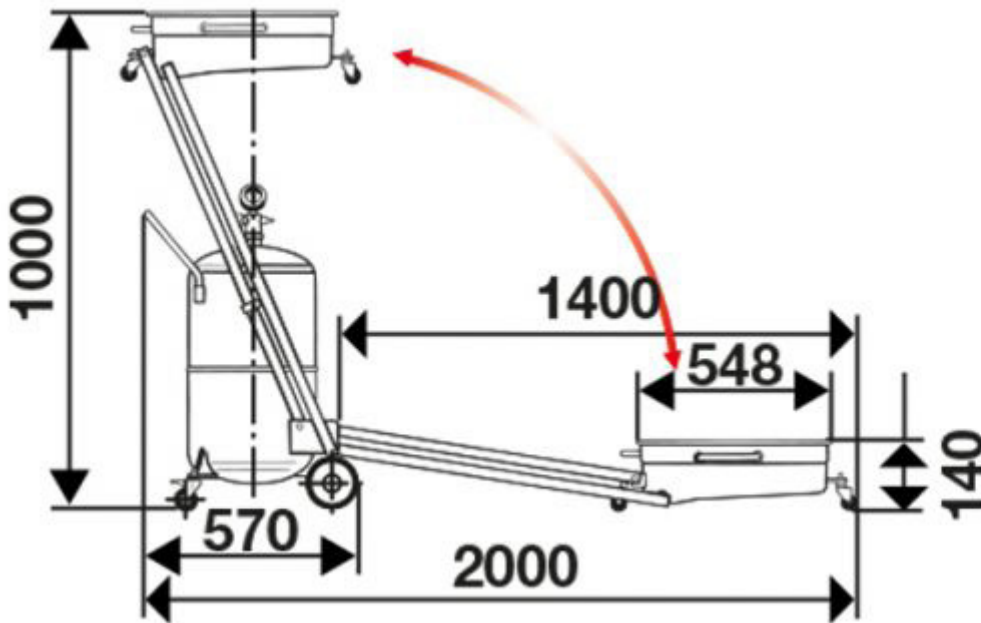

AF-RA-46065

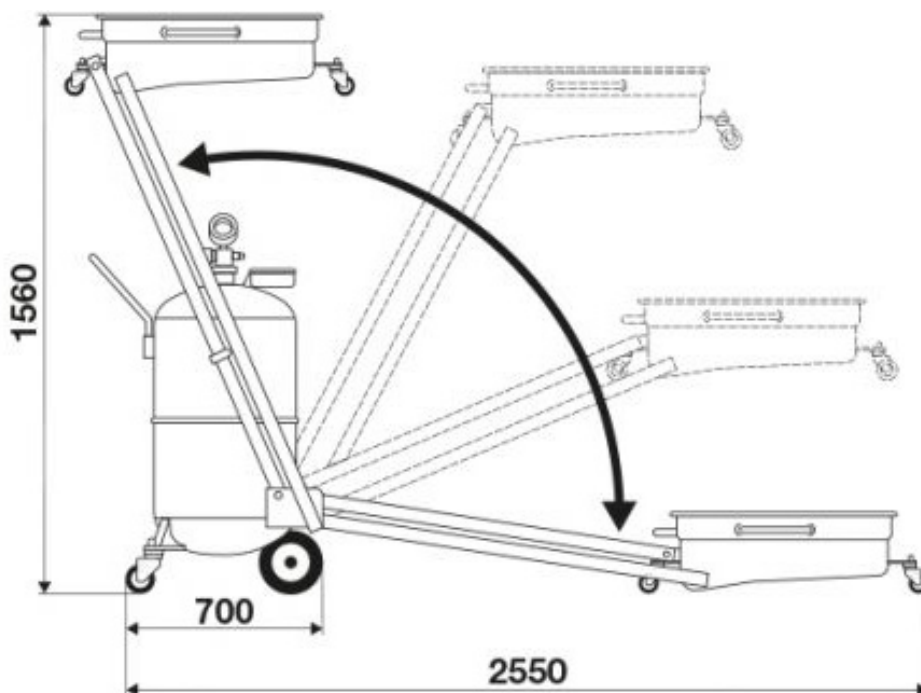
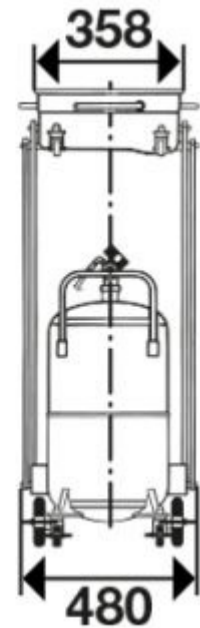

AF-RA-46215

